

Aqualex 16

AC/ACWG

AQUALEX

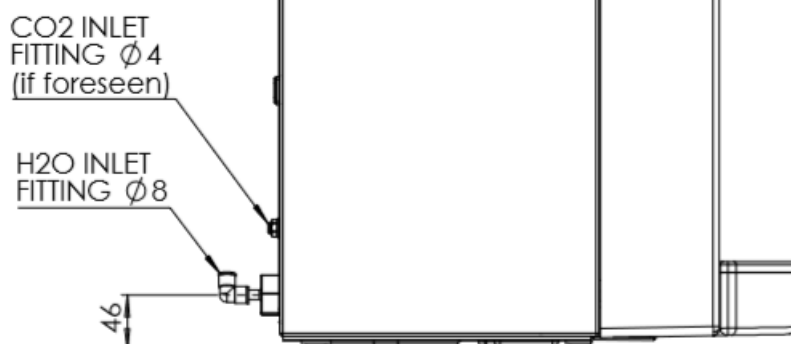
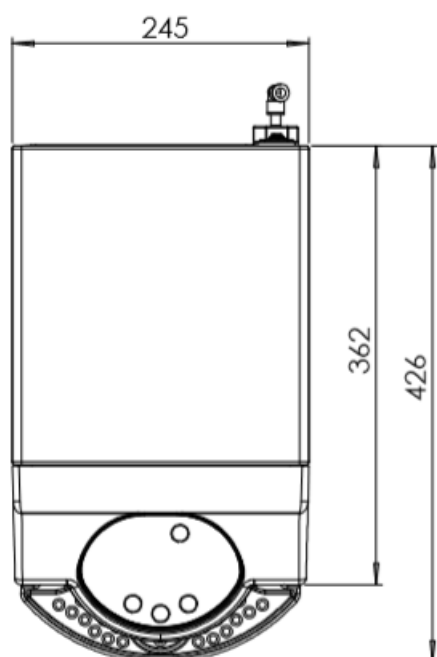
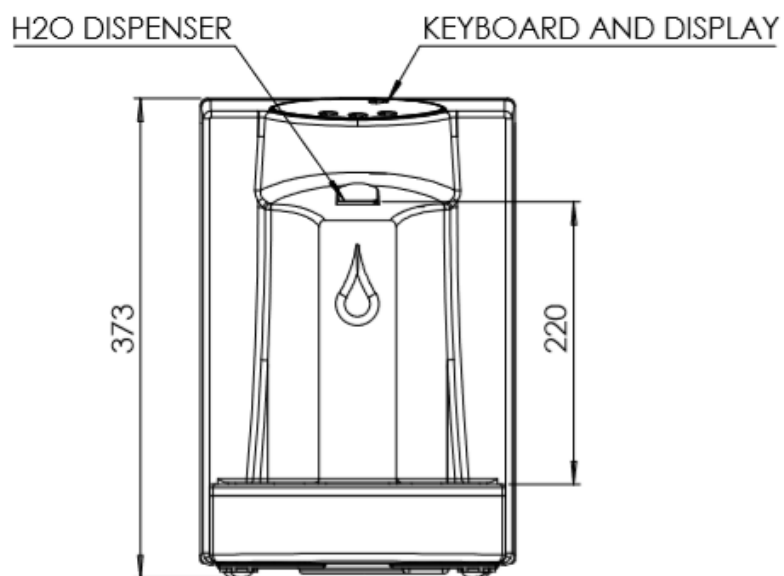

Aqualex 16

AC / ACWG

AQUALEX

Optioneel cabinet

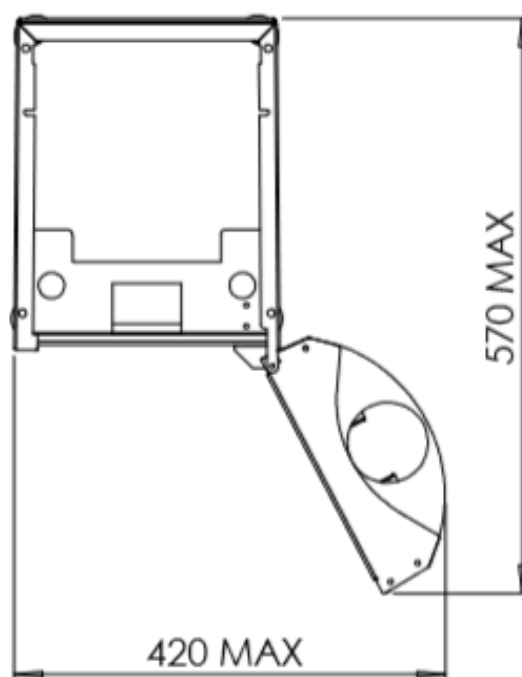
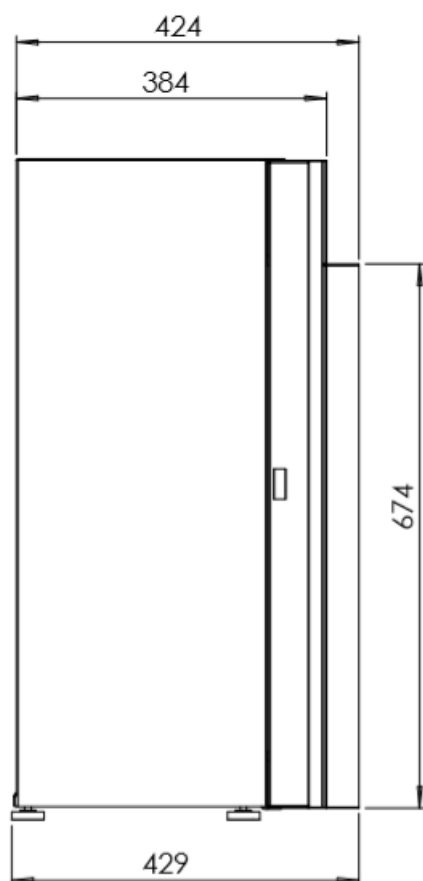
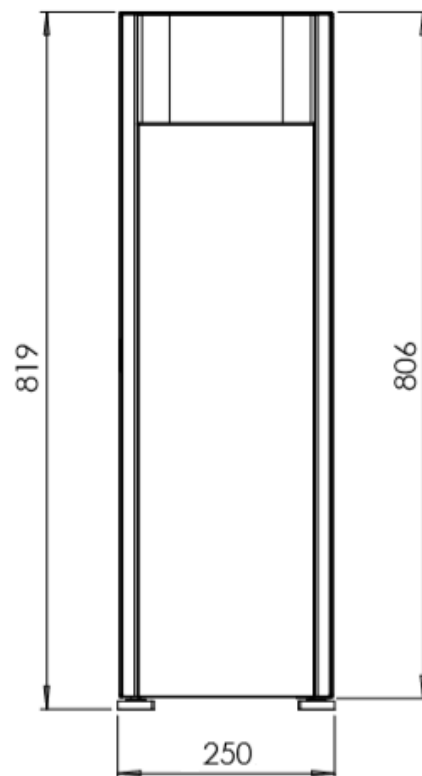

Aqualex 16

AC / ACWG

AQUALEX

CAPACITEITEN

CAPACITIES

	Per uur Per hour	In continu Continuously
Aqualex 16 AC	16L	10L*
Aqualex 16 ACWG	16L	10L*

Inkomend water 14°C
Incoming water 14°C

***Uitkomend gefilterd water varieert tussen 3-10°C**
**Outcoming filtered water varies between 3-10°C*

AFMETINGEN

DIMENSIONS

	l	b	h
Toestel / Device	420*	240	370
Cabinet	424	250	819

***5cm extra voorzien voor de installatie**
**Add 5cm for the installation*

TECHNISCHE INFORMATIE

TECHNICAL INFORMATION

Werkdruk water MIN-MAX <i>Pressure water MIN-MAX</i>	2.5 - 4bar
Koelgas hoeveelheid <i>Refrigerant gas quantity</i>	R134A 0,040 kg
Max. vermogen <i>Max. power</i>	AC: 150W ACWG: 230W
Inhoud lekbak <i>Drip tray capacity</i>	600ml
Hoogte Tappunt <i>Height dispensing outlet</i>	220mm
Cabinet <i>Cabinet</i>	Optioneel <i>Optional</i>

TECHNISCHE VOORZIENINGEN

TECHNICAL PROVISIONS

Stopcontacten <i>Sockets</i>	1 x 230V
Noodzakelijke watertoevoer <i>Necessary water supply</i>	3/4" dubbele dienstkraan met terugslagklep. <i>Double service tap with back valve</i>
Afvoer <i>Drain</i>	Geen afvoer mogelijk <i>No drainage possible</i>